

7/15/2011

BOT 1

9:15 a.m. -

1. **Roll Call**

2. **Approval of the Minutes of Previous Meetings**

Will the Board of Trustees approve the minutes of the meetings of the Board held on May 13, 2011?

3. **Informational Report by the President of the University**

10:00 a.m. -

4. **Informational Report on Penn State Lehigh Valley**

Dr. Ann M. Williams, Chancellor, will discuss the activities and achievements of Penn State Lehigh Valley as well as her vision for future directions of the campus.

5. **At Penn State University, People Come First**

Ms. Susan McGarry Basso, Associate Vice President for Human Resources, will provide information on the myriad ways that Penn State provides support for its employees, our most valuable resource.

6. **Operating Budget for the University for the Fiscal Year Beginning July 1, 2011**

Dr. Graham B. Spanier, President of the University, will provide a report on the 2011-2012 Operating Budget.

11:30 a.m. -

Walking tour of Penn State Lehigh Valley Campus followed by lunch in the Student Lounge/Café and Centre Hall, for Trustees and all persons invited to the meetings.

1:30 p.m. -

7. **Reports from Standing Committees**

Discussion of action and/or information items by the Standing Committees for consideration by the Board of Trustees:

A. **Committee on Campus Environment** - Michael DiBerardinis, Chair

B. **Committee on Educational Policy** - David M. Joyner, Chair

1) **Discussion of Consent Agenda Items Provided for Information or Approval of the Committee on Educational Policy:**

Information Items -

- a) Information on Undergraduate Programs
- b) Information on Graduate Programs

7. Reports from Standing Committees (Continued)**B. Committee on Educational Policy** - David M. Joyner, Chair (Continued)**1) Discussion of Consent Agenda Items Provided for Information or Approval of the Committee on Educational Policy:** (Continued)

Action Items - None

(See Appendix I)

C. Committee on Finance and Physical Plant - Linda B. Strumpf, Chair**1) Discussion of Consent Agenda Items Provided for Information or Approval of the Committee on Finance and Physical Plant:**

Information Items -

- a) Breazeale Reactor Renovations, University Park
- b) Davey/Carnegie/Rider Masonry Restoration, University Park
- c) Lacrosse Artificial Turf Field, University Park
- d) Bryce Jordan Center Scoreboard Video Package, University Park
- e) Capital Union Building Fitness Center Addition, Penn State Harrisburg
- f) Naming of Rooms, Portions of Buildings, and Plazas
- g) Purchase of Property Located at 118 North Butz Street, State College
- h) Status of Major Construction Programs and Borrowing

Action Items -

- i) Proposed Renewal of The Nittany Lion Inn Liquor License, Liquor Permit for Sunday Sales and Amusement Permit
- j) Summary of Revisions to Existing Scholarships, Fellowships, Etc.
- k) Acknowledgments of Endowments and Other Major Commitments

(See Appendix II)

2) Proposed Naming of the New Classroom Building "Gaige Technology and Business Innovation Building," Penn State Berks

The Facilities Naming Committee has recommended that the Board of Trustees name the new classroom building at Penn State Berks, the "Gaige Technology and Business Innovation Building" in honor of the late Dr. Fredrick H. Gaige who served for 17 years as the second CEO of the campus.

Will the Committee on Finance and Physical Plant recommend to the Board of Trustees adoption of the following resolution:

RESOLVED, That the new classroom building at Penn State Berks is named the "Gaige Technology and Business Innovation Building."

(See Appendix III)

7. Reports from Standing Committees (Continued)**C. Committee on Finance and Physical Plant - Linda B. Strumpf, Chair** (Continued)**3) Consideration of Proposed Operating Budget for the University for the Fiscal Year Beginning July 1, 2011**

Will the Committee on Finance and Physical Plant recommend to the Board of Trustees adoption of the following resolution:

RESOLVED, That the proposed Operating Budget for the University for the fiscal year beginning July 1, 2011, as shown in Attachment I and Schedules I - V which are attached hereto and made a part hereof, is approved.

(Operating Budget attachment and schedules will be distributed to Trustees under separate cover.)

4) Proposed Tuition and Fees Effective 2011 Fall Semester, The Pennsylvania State University

Will the Committee on Finance and Physical Plant recommend to the Board of Trustees adoption of the following resolution:

RESOLVED, That tuition and fees at all locations are, effective 2011-2012 school year, as shown on the statements attached hereto and which are a part of this resolution.

(Tuition statement attachment will be distributed to Trustees under separate cover.)

5) Proposed Appointment of Designer, Beaver Stadium Scoreboard Upgrades, University Park

The Subcommittee on Architect/Engineer Selection will make a report and recommendation on the appointment of a designer for Beaver Stadium Scoreboard Upgrades at University Park.

6) Photo Report on Selected Construction Projects

A photo report on the progress of selected construction projects will be presented at the meeting.

8. Legal Matters

Cynthia A. Baldwin, Vice President and General Counsel, will present an informational report on pending University legal matters and/or policies normally considered by a Standing Committee of the Board.

9. Election of Members to the Board of Directors: Agricultural Law Resource and Reference Center, The Dickinson School of Law of The Pennsylvania State University

The Agricultural Law Resource and Reference Center was established in 1998, following the July 1, 1997, affiliation of The Dickinson School of Law with The Pennsylvania State University. The Center is a collaboration between Penn State's Dickinson School of Law and the College of

9. **Election of Members to the Board of Directors: Agricultural Law Resource and Reference Center, The Dickinson School of Law of The Pennsylvania State University** (Continued)

Agricultural Sciences and is funded, in part, by the Pennsylvania Department of Agriculture. The Center is designed to provide the highest-quality educational programs, information, and materials to those involved or interested in the agricultural industry.

The Board of Directors of the Center is comprised of: the Secretary of the Pennsylvania Department of Agriculture; the Dean of the Dickinson School of Law; the Dean of the College of Agricultural Sciences; the chairman and the minority chairman of the Agriculture and Rural Affairs Committee of the Senate (or their designees); the chairman and the minority chairman of the Agriculture and Rural Affairs Committee of the House of Representatives (or their designees); two members of the Board of Trustees of The Pennsylvania State University who serve by virtue of election; and the vice president who serves as director for cooperative extension at The Pennsylvania State University. In addition, the Board includes the following members appointed by the Secretary of Agriculture: three representatives of production agriculture, one of whom must be a direct marketer; one agricultural processor; one representative of an agribusiness who must have experience with producer contracts; and one attorney with expertise in agricultural law.

In 2010, the Board of Trustees elected Trustees Samuel E. Hayes, Jr. and Betsy E. Huber to serve as directors for one-year terms. As their terms have expired, it is desirable to reelect Samuel E. Hayes, Jr. and Betsy E. Huber as directors for one-year terms.

Will the Board of Trustees of The Pennsylvania State University adopt the following resolution:

RESOLVED, That the Board of Trustees elects Trustee Samuel E. Hayes, Jr. and Trustee Betsy E. Huber to serve on the Board of Directors of the Agricultural Law Resource and Reference Center of The Dickinson School of Law of The Pennsylvania State University.

10. **Informational Report on *For the Future: The Campaign for Penn State Students***

Mr. Peter G. Tombros, Chair of *For the Future: The Campaign for Penn State Students*, will present an informational report on the Campaign and University Development.

11. **Informational Report on the Penn State Alumni Association Activities by the President of the Alumni Association**

A report on the activities of the Penn State Alumni Association will be presented by Mr. Barry M. Simpson, President of the Penn State Alumni Association for 2010-2011.

12. **Announcements by the Chairman of the Board of Trustees**

1. Information on Undergraduate Programs

A. University College and College of the Liberal Arts

1) College of the Liberal Arts, Law and Liberal Arts Minor, Penn State Brandywine: Drop of Minor

Low enrollments support the decision to discontinue the Law and Liberal Arts Minor at Penn State Brandywine. All students currently in the program will have a reasonable opportunity to complete the minor. There will be no impact on tenure track faculty. The elimination of the minor will become effective Fall 2011.

B. College of Communications

1) Media Law and Policy Option in Bachelor of Arts in Media Studies: Drop of Option and Change in Name of General Option to Society and Culture Option

The Media Law and Policy Option in Media Studies is being dropped due to low student enrollment. The name of the General Option will be changed to Society and Culture Option, which reflects the option's curriculum. The changes will become effective Fall 2011.

C. College of Engineering

1) Associate in Engineering Technology in Surveying Technology: Change in Name

The Associate in Engineering Technology in Surveying Technology name will be changed to Associate in Engineering Technology in Surveying Engineering Technology. The name change accurately describes the program content as engineering technology. The name change will become effective Fall 2011.

D. Penn State Harrisburg

1) Homeland Security Minor: New Program

The new minor in Homeland Security instructs students in homeland security and defense issues, including emergency management, homeland security policy, and the structure of homeland security operations. The new minor will become effective Fall 2011.

2. Information on Graduate Programs

A. Master of Agriculture Degree from the Graduate Program in Horticulture, College of Agricultural Sciences: Drop of Program

The proposal to drop the Master of Agriculture degree from the graduate program in Horticulture offered by the College of Agricultural Sciences was approved by the Graduate Council at its May 11, 2011 meeting.

The Master of Agriculture degree is being dropped due to low enrollment as recommended during a Graduate Program Review in 2004. The Academic Program and Administrative Services Core Council also recommended dropping this program in their letter of recommendations for the College of Agricultural Sciences on January 12, 2011.

B. Applied Mathematics Option and the Logic option from the Ph.D. Degree Program in Mathematics, Eberly College of Science: Drop of Options

The proposal to drop the Applied Mathematics option and the Logic option from the Ph.D. degree program in Mathematics offered by the Eberly College of Science was approved by the Graduate Council at its May 11, 2011 meeting.

2. **Information on Graduate Programs** (Continued)

- B. Applied Mathematics option and the Logic Option from the Ph.D. Degree Program in Mathematics, Eberly College of Science: Drop of Options (Continued)

These formal options were added to the Ph.D. program in order for students to select/specify which Ph.D. qualifying examinations they would be taking: pure, applied or logic exams. These examinations were changed Fall 2008 and are, thus, obsolete.

- C. Biomolecular Transport Dynamics Option in the Graduate Program in Chemical Engineering, College of Engineering: Drop of Option

The proposal to drop the Biomolecular Transport Dynamics option in the graduate program in Chemical Engineering offered by the College of Engineering was approved by the Graduate Council at its April 20, 2011 meeting.

The option was offered in conjunction with the Integrative Biosciences [IBIOS] Graduate Degree Program. The IBIOS Program decided to drop this option in 2005 due to the departures of the key faculty and lack of student interest in this program. The majority of the courses required for this are no longer being offered at Penn State, and none of the current Chemical Engineering faculty conduct research in this area.

- D. Dual-Title Graduate Degree Program in Bioethics, College of the Liberal Arts and Adoption of the Dual-Title Degree Program by the Graduate Program in Anthropology (College of the Liberal Arts), the Graduate Program in Biobehavioral Health (College of Health and Human Development), and the Graduate Program in Communication Arts and Sciences (College of the Liberal Arts): New Program

The proposal to create a dual-title graduate degree program in Bioethics offered by the College of the Liberal Arts, and adoption of the dual-title degree program by the graduate program in Anthropology (College of the Liberal Arts), the graduate program in Biobehavioral Health (College of Health and Human Development), and the graduate program in Communication Arts and Sciences (College of the Liberal Arts) was approved by the Graduate Council at its May 11, 2011 meeting.

The objective of the proposed program is to enhance the bioethics curriculum and establish Penn State as a leading center of bioethics scholarship and graduate education. Such training is of great and growing value to students across many disciplines as society strives to come to terms with increasingly complex issues associated with the practice of medicine, access to and delivery of health care, the power of bioscience and technology, and the ways in which biomedical research is funded and conducted. Graduates of the program will be uniquely qualified to compete for jobs on the cutting edge of science, ethics and policy.

- E. Master of Business Administration/MD Joint-Degree Program, The Mary Jean and Frank P. Smeal College of Business and the College of Medicine: New Program

The proposal to create a Master of Business Administration/MD joint-degree program offered by The Mary Jean and Frank P. Smeal College of Business and the College of Medicine was approved by the Graduate Council at its April 20, 2011 meeting.

The objective of the joint degree MD/MBA program is to train medical doctors as both good clinicians and skilled business analysts. Interested individuals could range from those who expect to run a hospital, to those who want to work for a major pharmaceutical or biotech firm, to those who want to assume a public policy role in healthcare. The deans at both College of Medicine and The Mary Jean and Frank P. Smeal College of Business believe a joint degree program should be offered in order to be competitive with other top tier medical schools.

2. **Information on Graduate Programs** (Continued)

- F. Nurse Practitioner Option in the Master of Science in Nursing: Change to Family Nurse Practitioner Option and the Adult Gerontology Option; and Change to Base Program of the Master of Science in Nursing

The proposal to change the Nurse Practitioner Option in the Master of Science in Nursing to create two new options, the Family Nurse Practitioner Option and the Adult Gerontology Option; and to change the the requirements for the base program in the Master of Science in Nursing was approved by the Graduate Council at its April 20, 2011 meeting.

These updates/changes are being undertaken to incorporate new national standards and certification/licensure requirements for both the Nurse Practitioner and Clinical Nurse Specialist options.

1. Breazeale Reactor Renovations, University Park

The University intends to renovate 8,000 square feet of classroom and lab space on two stories of the Breazeale Nuclear Reactor building. The project will include a new elevator to provide for ADA compliance and will update all mechanical, electrical, and plumbing systems associated with the west wing of the facility. Renovations will be complete by the Fall 2012. There will be no exterior changes to the building. The cost estimate for this project is \$3,613,000.

(See Appendix II.1)

2. Davey/Carnegie/Rider Masonry Restoration, University Park

The University intends to restore deteriorated exterior masonry elements on three University Park buildings. The project includes mortar joints in the terra cotta façade of Carnegie, cleaning relief angles and installing new flashing at Davey Lab, and replacing brick window heads and sills at Rider Building. All failed building sealing joints will be replaced. The cost estimate for this project is \$1,027,000.

(See Appendix II.2)

3. Lacrosse Artificial Turf Field, University Park

The University intends to install an artificial turf lacrosse field west of the Multisport Indoor Facility to replace the current field slated to be demolished for the new Ice Arena. The site will be excavated to the same elevation as the event level of the Multisport Indoor Facility. Scored concrete pavement will allow at-grade access to the building, access for field maintenance vehicles and placement of existing bleachers. The project also includes a scoreboard and lighting. The cost estimate for this project is \$4,950,000.

(See Appendix II.3)

4. Bryce Jordan Center Scoreboard Video Package, University Park

The University intends to install a complete center hung video package at the Bryce Jordan Center. The package includes the primary LED video display, LED ring displays, LED courtside display, and courtside LED display table. The project scope includes processing and control, operating system, training, and warranty. The cost estimate for this project is \$1,300,000.

(See Appendix II.4)

5. Capital Union Building Fitness Center Addition, Penn State Harrisburg

An approximately 12,500 square foot glass-encased addition will be constructed on the east side of the existing Capital Union Building at Penn State Harrisburg with a project cost estimate of \$4,750,000. The two-story addition will include a new fitness center, four team-locker rooms, officials' locker rooms and support spaces. The project includes upgraded electrical and gas services, and minor site improvements.

(See Appendix II.5)

6. Naming of Rooms, Portions of Buildings and Plazas

The Facilities Naming Committee has made certain recommendations to the President on the naming of rooms, portions of buildings and plazas. In accordance with the Policy on Naming University Facilities, the Board of Trustees is hereby informed that the President has approved the following naming actions:

- A. The main entrance/lobby, Pegula Ice Arena, the "Silvis Family Lobby" for a commitment from Paul and Nancy Silvis.
- B. The men's ice hockey head coach's office, Pegula Ice Arena, the "Joseph M. Battista Head Coach's Office" for a gift from John and Karen Davis.

6. **Naming of Rooms, Portions of Buildings and Plazas** (Continued)

- C. The assistant football trainer's office, 109K Lasch Football Building, the "Cindy K. Iacocca Assistant Football Trainer's Office" for a commitment from Cindy K. Iacocca.
- D. The football administrator's office, room 202B Lasch Football Building, the "Gibson-Thomas Engineering Co., Inc., Football Administrator's Office" for a commitment from Gibson-Thomas Engineering Co., Inc.
- E. The Power Lab Room, Room W5 in the Olmsted Building, Penn State Harrisburg, the "PPL Electric Utilities Power Laboratory for a gift from PPL Electric Utilities.
- F. A music classroom, Room 111, Penn State Lehigh Valley, for a gift in honor of the parents of Mark Markowitz and family. The recognition plaque should read:

*Jerome and Martha Markowitz Music Room
In recognition of their contributions to the world of music*

- G. A classroom, Room 309, Penn State Lehigh Valley, for a gift from the Cohen Family. The recognition plaque will read:

*This classroom named in recognition of generous support from The Cohen Family,
Martye, Beth, Jason, Julie, Sarah Katie and Jessie*

- H. A conference room, Room 130, Penn State Lehigh Valley, for a commitment from Ann M. Williams. The recognition plaque should read:

In honor of Dr. Thomas P. and Elizabeth Williams by the Williams Family

- I. A conference room, Room 131, Penn State Lehigh Valley, for a commitment from Ann M. Williams. The recognition plaque should read:

From Ann M. Williams and Family

7. **Purchase of Property Located at 118 North Butz Street, State College**

In April 2011, the University purchased a .17 acre property including a 1,400 square foot residence adjoining University property, located at 118 North Butz Street, State College, Centre County, from Jennifer S. Kissell /now Jennifer S. Hoover for \$180,000. While the University will lease the residential property for an interim period, the purchase provides strategic campus expansion opportunities.

(See Appendix II.6)

8. **Status of Major Construction Programs and Borrowing**

(See Appendix II.7)

9. **Proposed Renewal of The Nittany Lion Inn Liquor License, Liquor Permit for Sunday Sales and Amusement Permit**

Will the Committee on Finance and Physical Plant recommend to the Board of Trustees adoption of the following resolution:

WHEREAS, It is the desire of The Pennsylvania State University to be granted a renewal Hotel Liquor License, and

WHEREAS, It is the desire of The Pennsylvania State University to be granted a renewal of Sunday Sales Permit for the sale of alcoholic beverages at The Nittany Lion Inn, and

WHEREAS, It is the desire of The Pennsylvania State University to be granted a renewal of Amusement Permit,

THEREFORE BE IT RESOLVED, That applications of License and Permits to expire January 31, 2013, be filed with The Pennsylvania Liquor Control Board and that Joseph J. Doncsecz, Corporate Controller, and Albert G. Horvath, Senior Vice President for Finance and Business/Treasurer, be authorized and any and all are authorized to execute the necessary applications and bond, and any other papers required by the Pennsylvania Liquor Control Board.

10. **Summary of Revisions to Existing Scholarships, Fellowships, Etc. (For the period April 18, 2011 through June 17, 2011)**

Will the Committee on Finance and Physical Plant recommend to the Board of Trustees adoption of the following resolution:

RESOLVED, That the conditions governing certain existing scholarships, fellowships, awards, and similar funds previously established at the University be revoked and that the Officers of the University are authorized to put into effect the revised regulations as requested by the donors.

11. **Acknowledgments of Endowments and Other Major Commitments**

The Committee on Finance and Physical Plant is advised that for the period April 18, 2011, through June 17, 2011, 58 new funds totaling approximately \$2,563,524 were accepted by the University, including scholarships, fellowships, etc. All of these items conform to established University policies and regulations.

For the period March 1, 2011 through April 30, 2011, 60 major commitments were accepted by the University totaling approximately \$31,440,605.

Will the Committee on Finance and Physical Plant recommend to the Board of Trustees adoption of the following resolutions:

RESOLVED, That the Board of Trustees gratefully acknowledges the generous contributions of the many friends of the University in support of endowments, funds, and other major commitments as reported to the Committee on Finance and Physical Plant at its meeting of July 15, 2011.

FURTHER BE IT RESOLVED, That the Officers of the University are authorized to convey the Board's appreciation to these generous benefactors who provide opportunities for many students to receive a quality education.

University Park

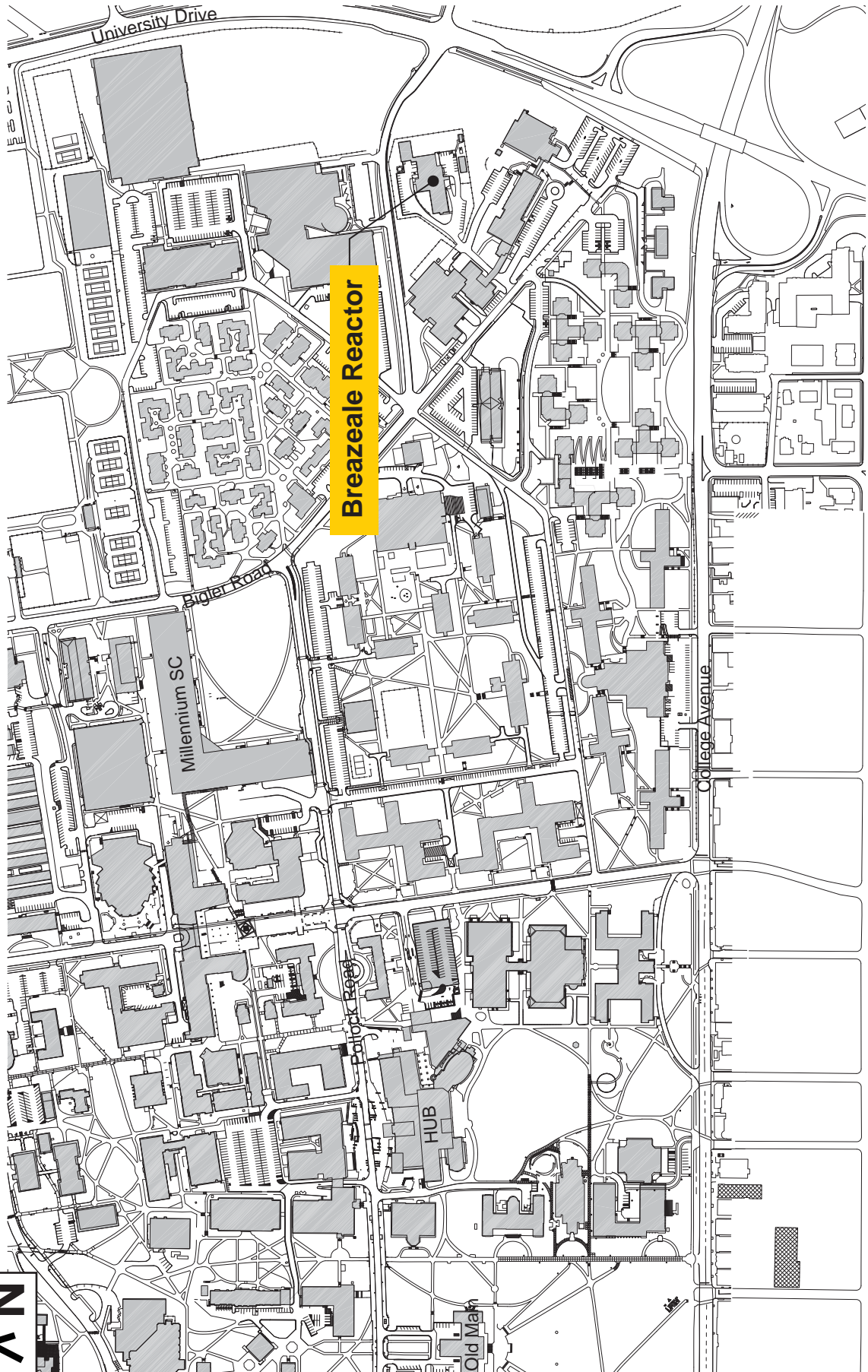

University Park



Breazeale Reactor West Wing - Existing First Floor

University Park



Limit of Work

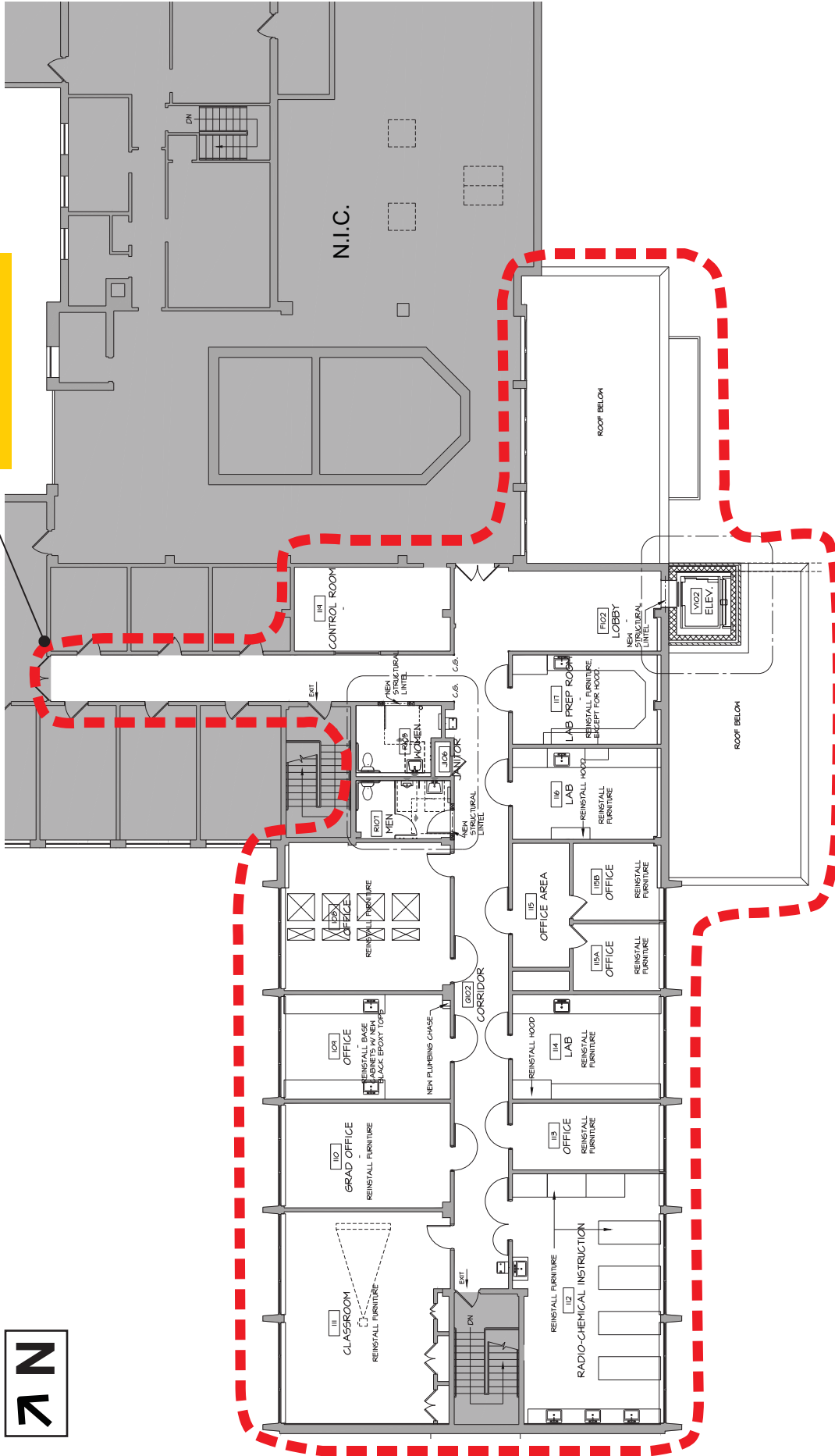

Breazeale Reactor West Wing - Proposed First Floor

(Appendix II.1)

University Park

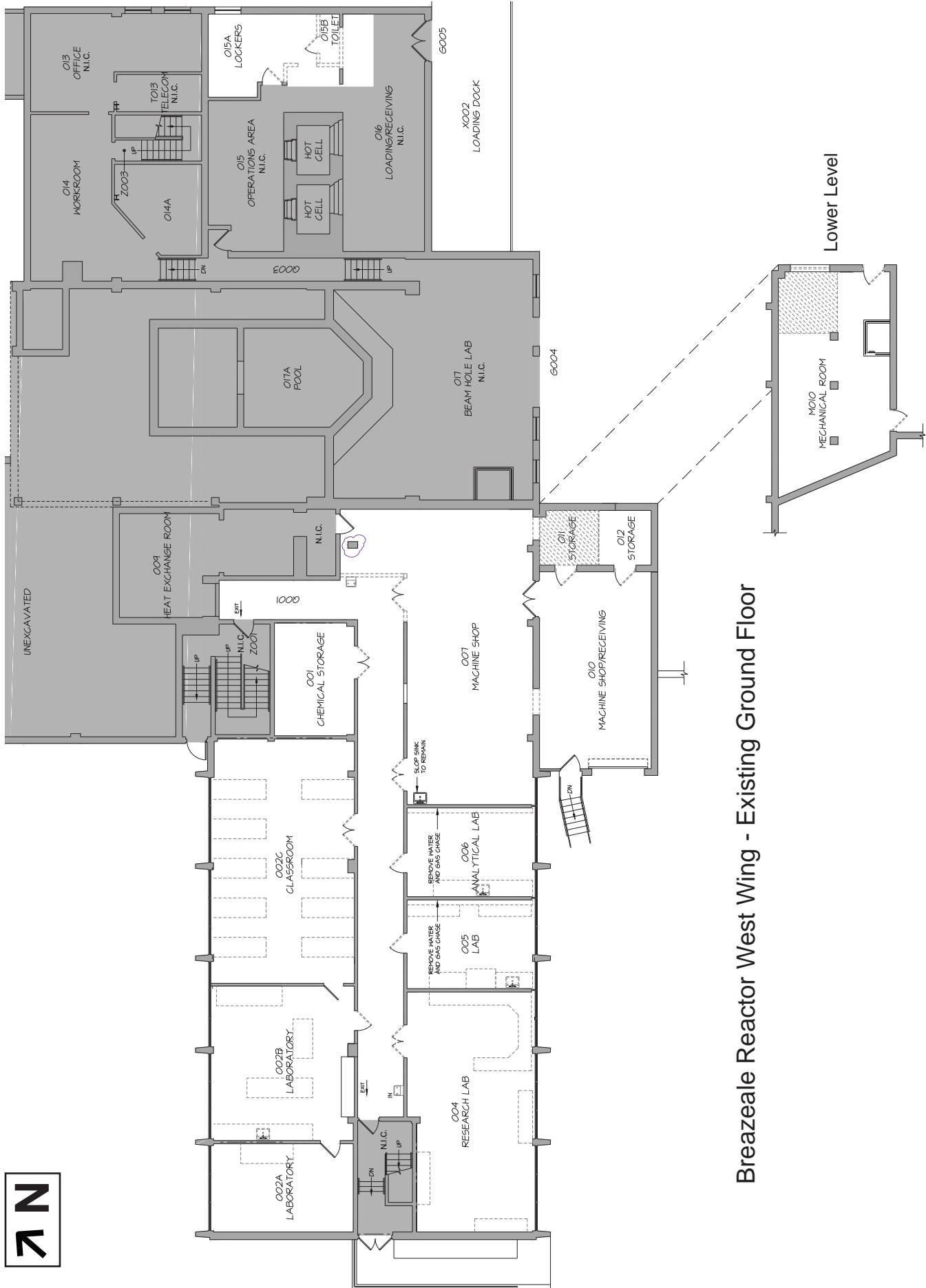

(Appendix II.1)

Breazeale Reactor West Wing - Existing Ground Floor

University Park



Limit of Work

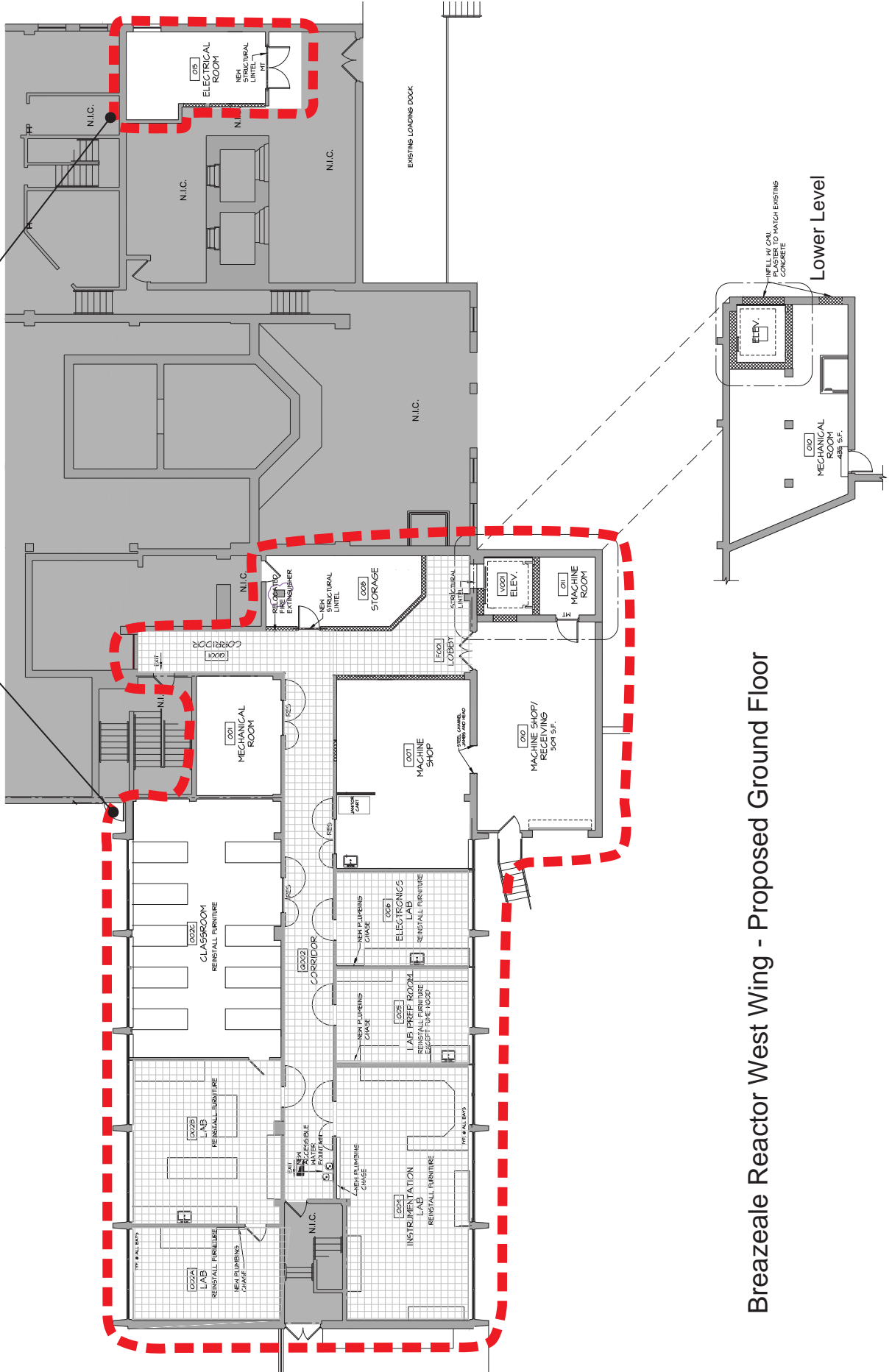

Breazeale Reactor West Wing - Proposed Ground Floor

University Park

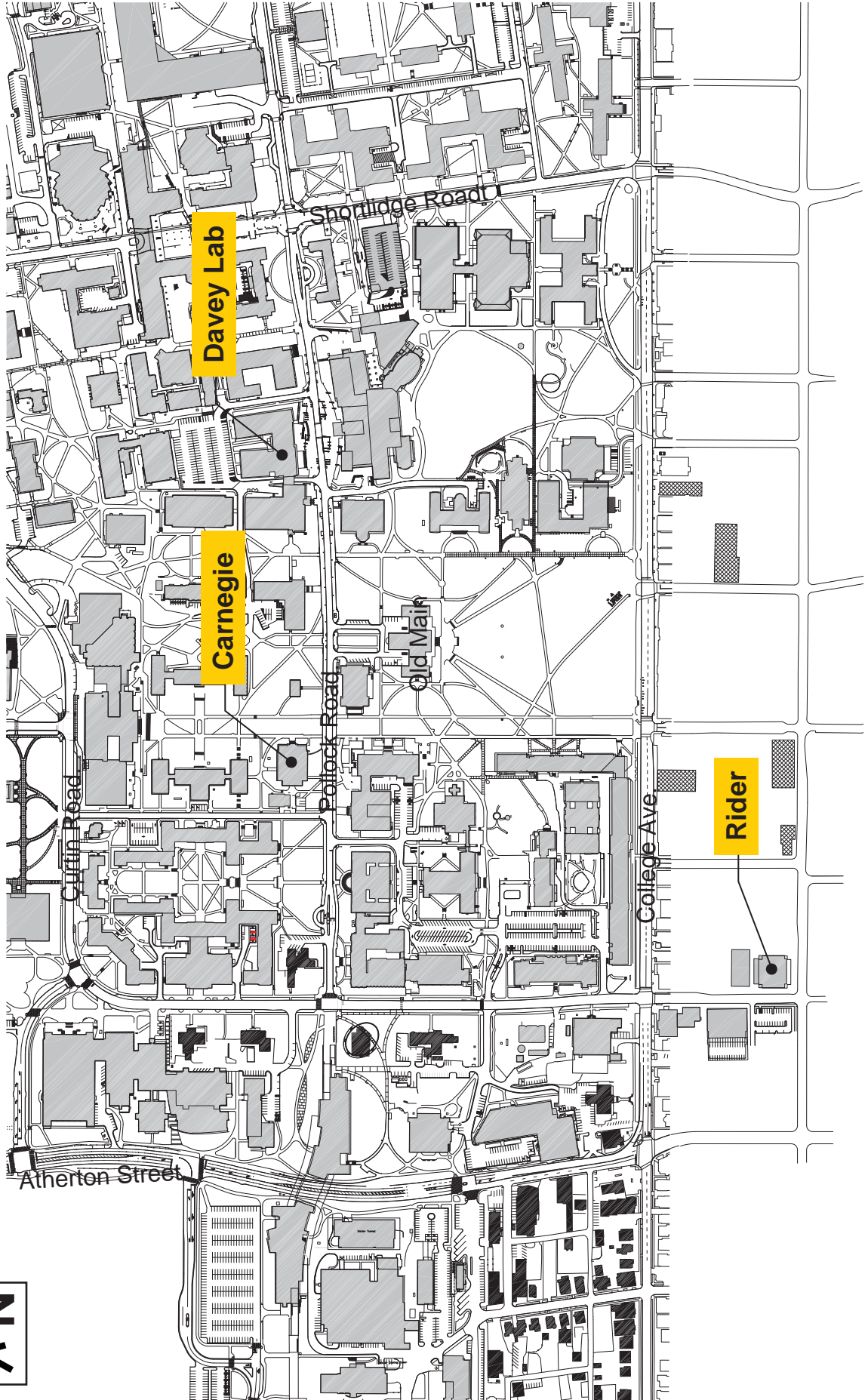

Penn State University Park

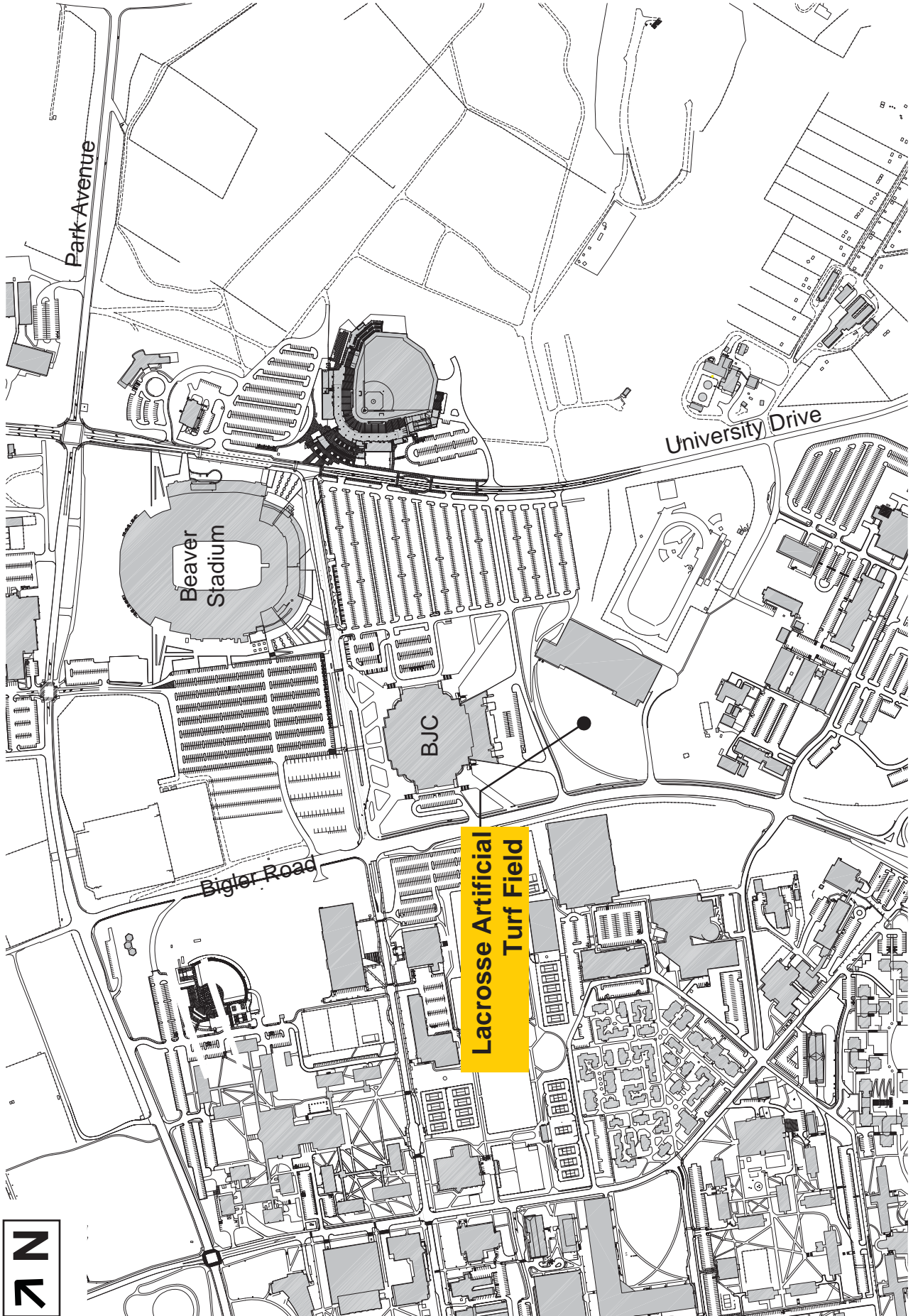

Penn State University Park



University Park

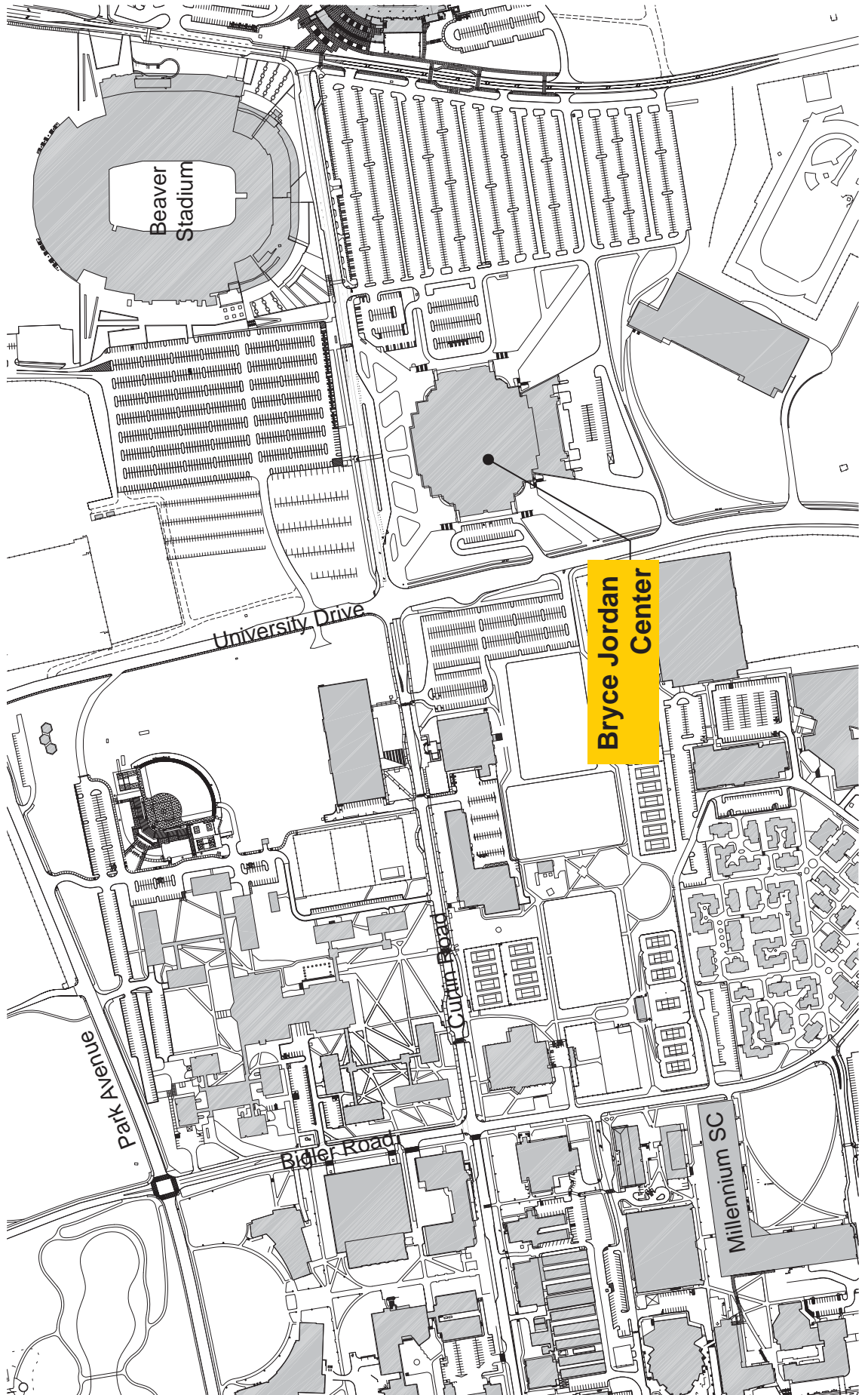

University Park

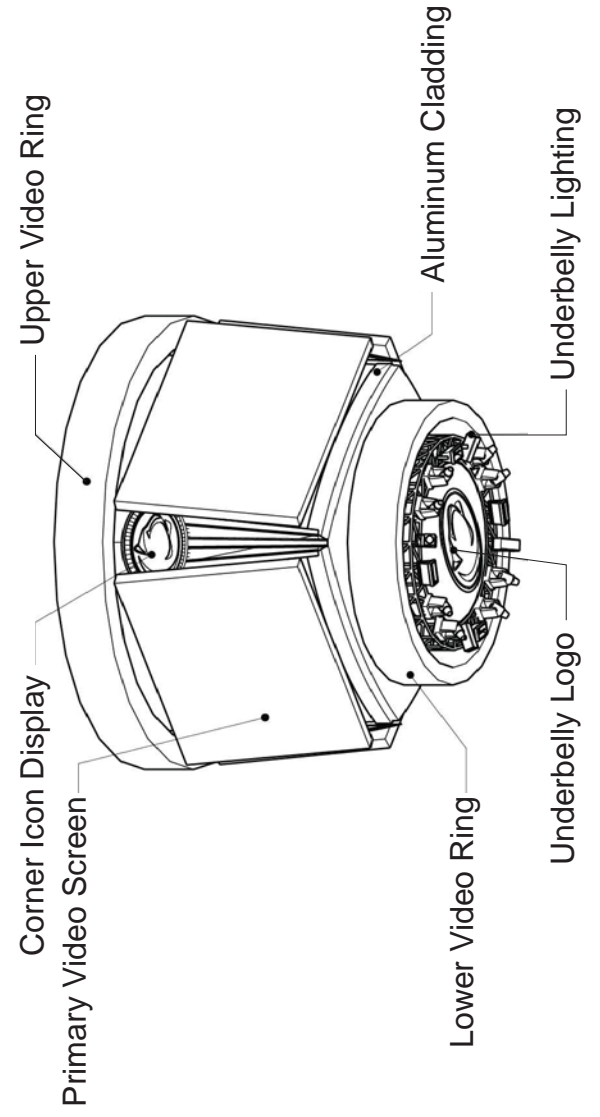

Penn State Harrisburg

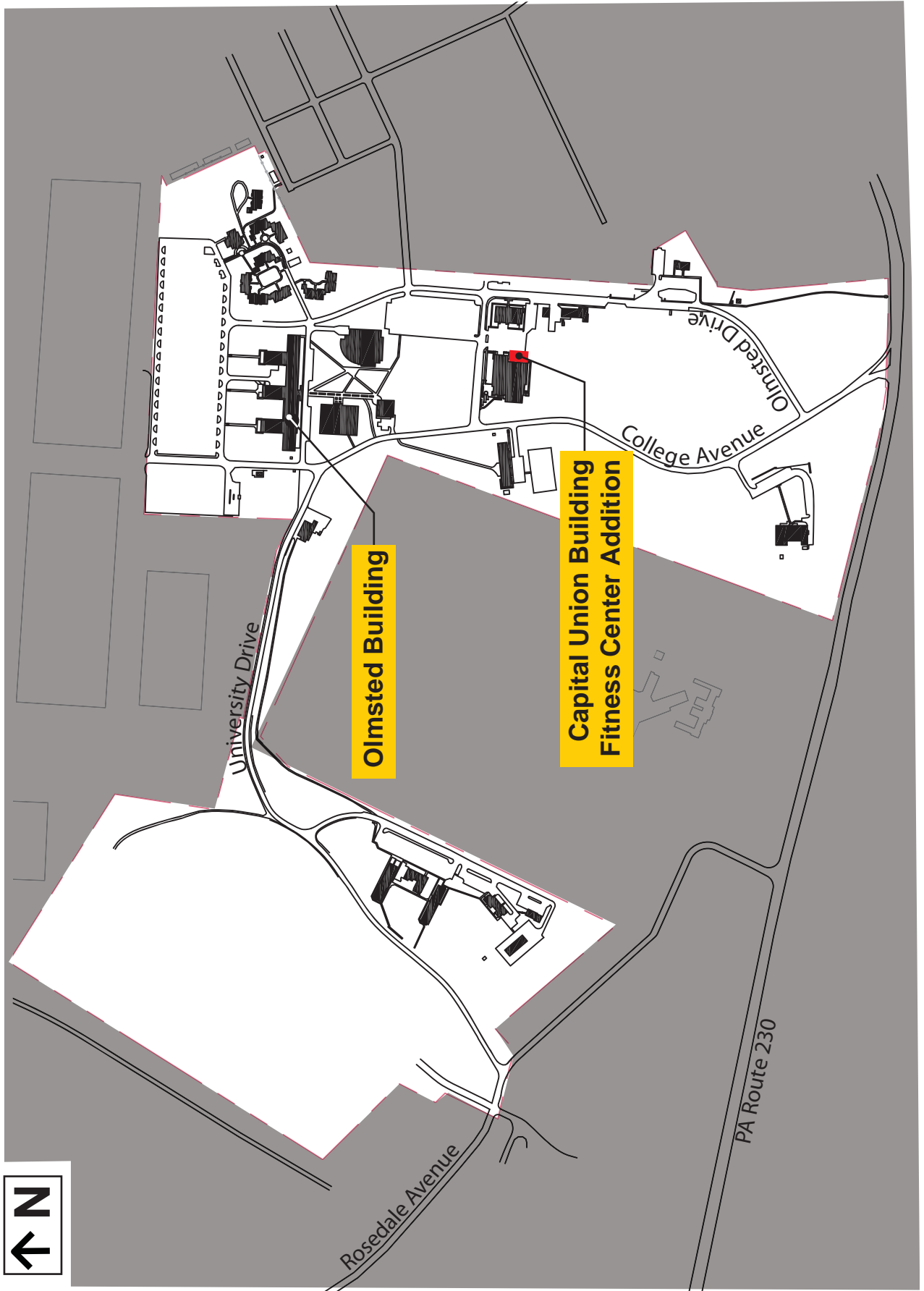

Penn State Harrisburg



East Side of the Capital Union Building - Existing Condition

Penn State Harrisburg

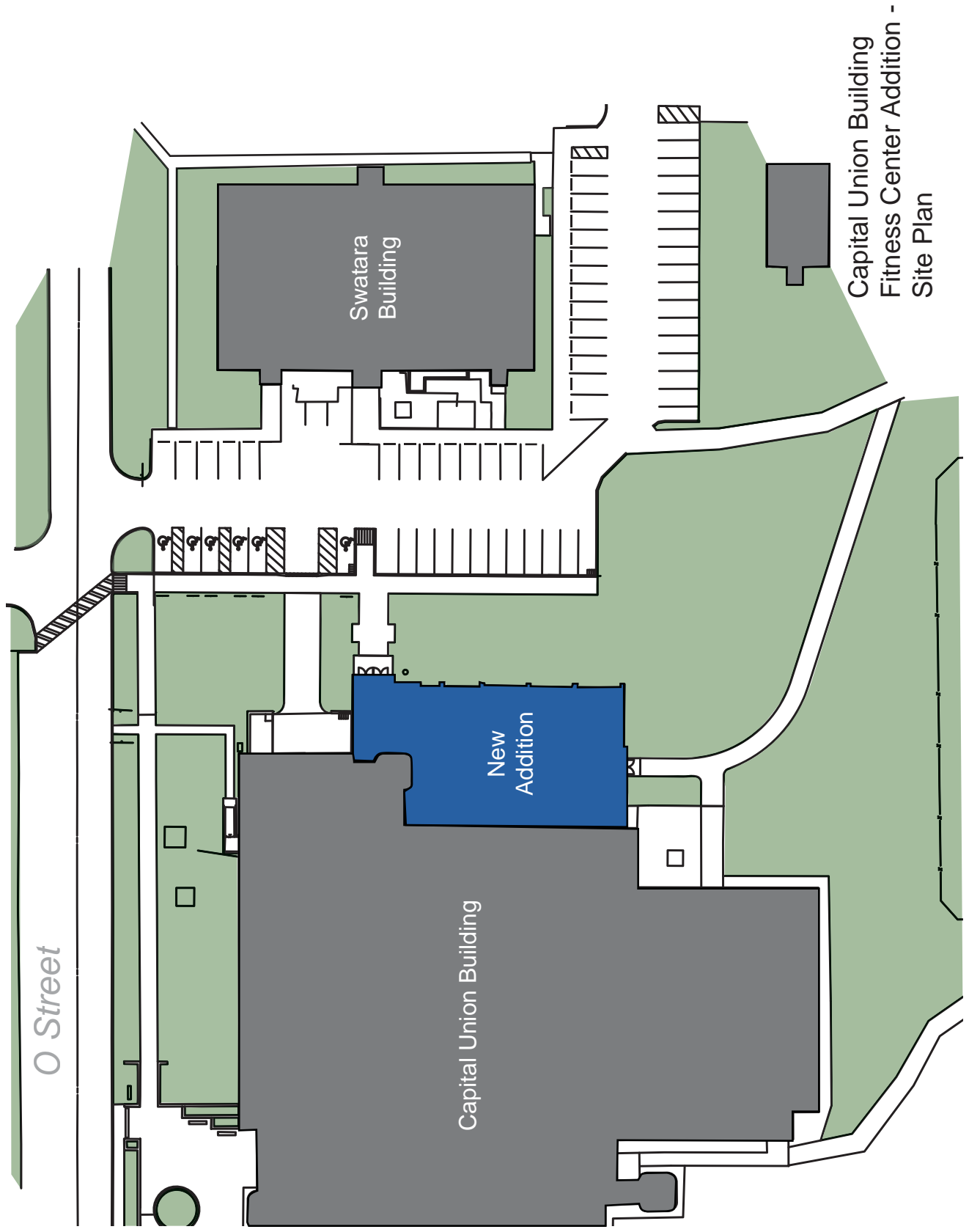

Penn State Harrisburg



Limit of Work

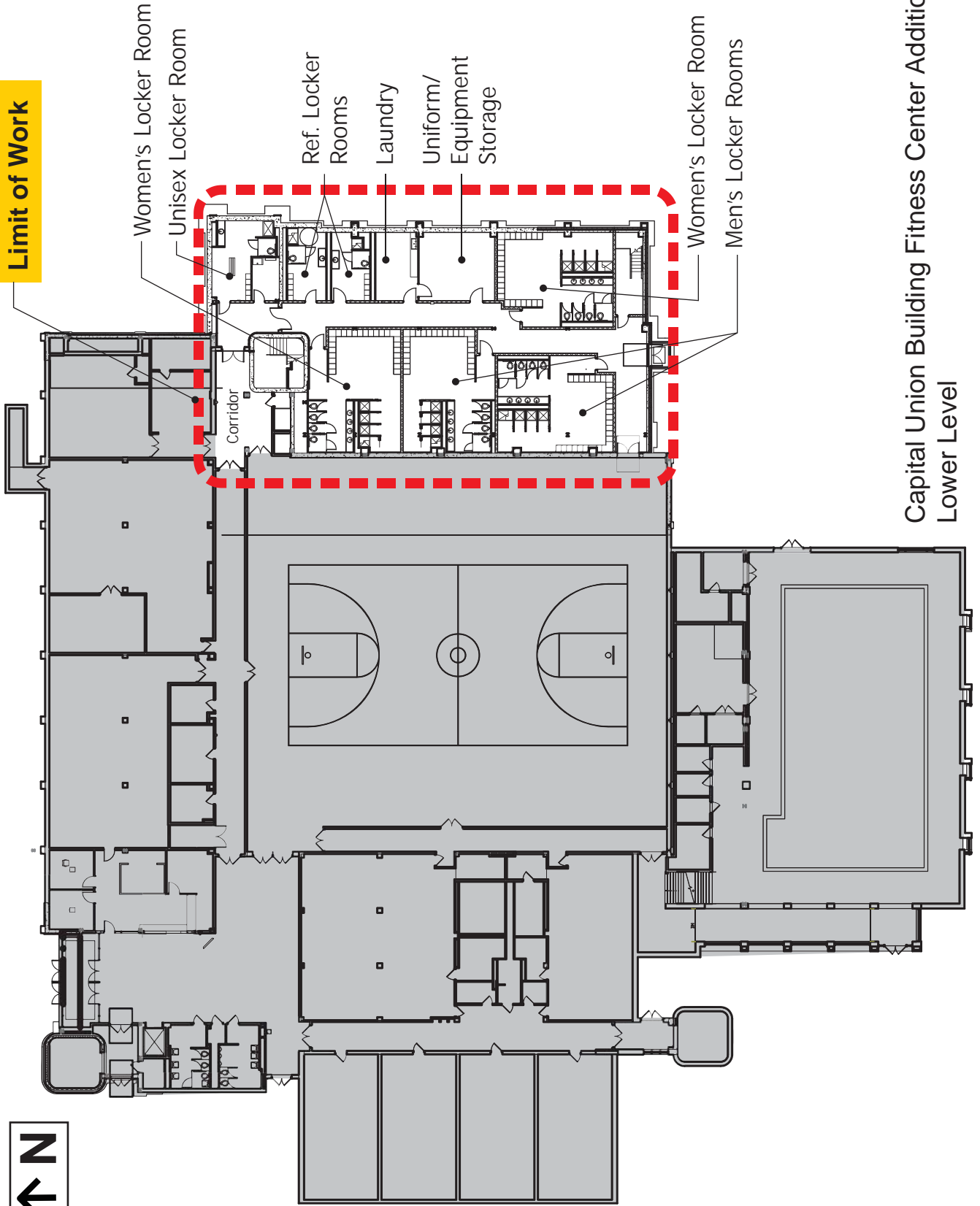

Capital Union Building Fitness Center Addition
Lower Level

Penn State Harrisburg

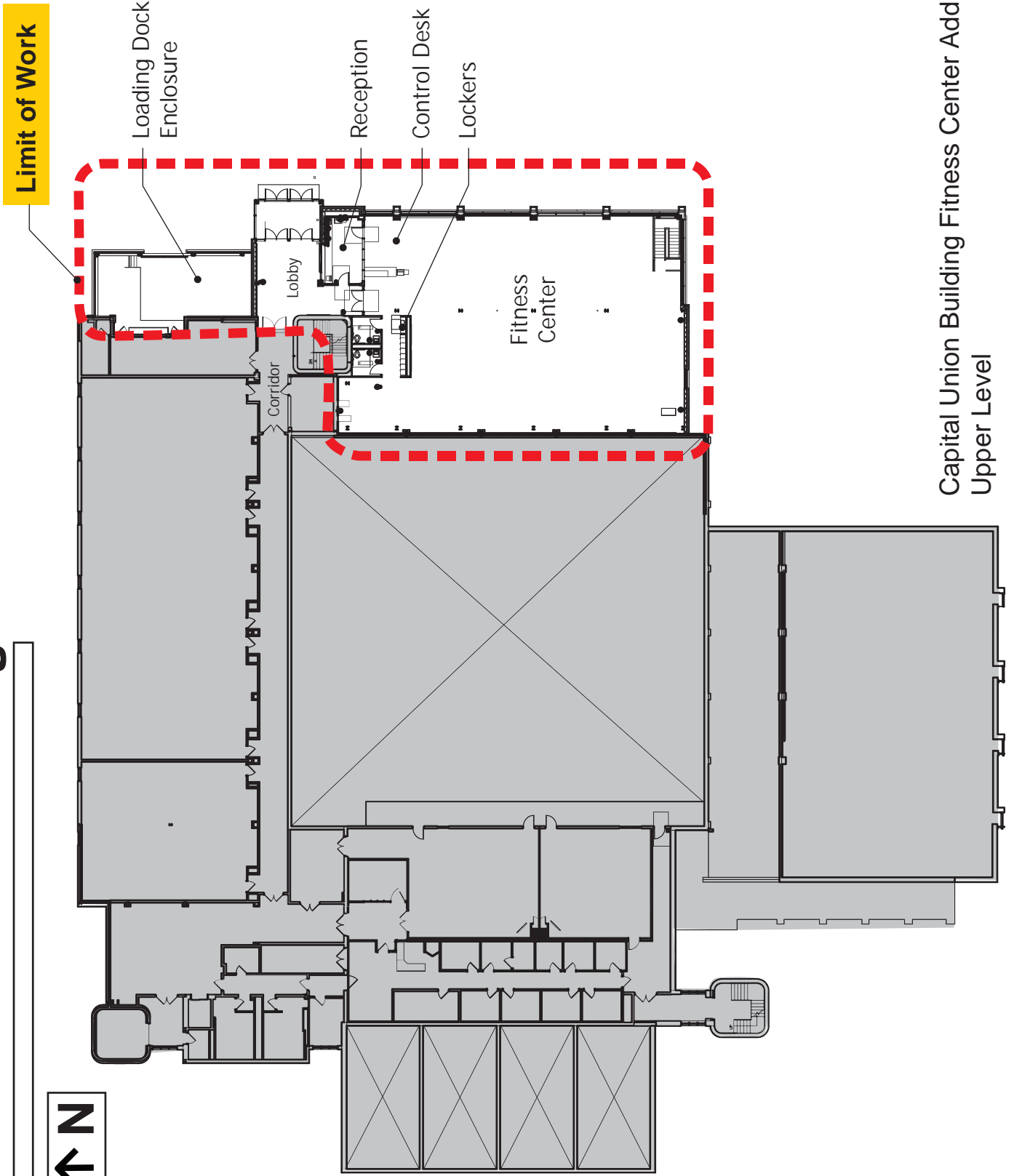

Capital Union Building Fitness Center Addition
Upper Level

Penn State Harrisburg

7/15/2011

F&PP



Capital Union Building Fitness Addition - Entrance View

Penn State Harrisburg

7/15/2011

F&PP



Capital Union Building Fitness Addition - Southeast View

(Appendix II.5)

Penn State University Park

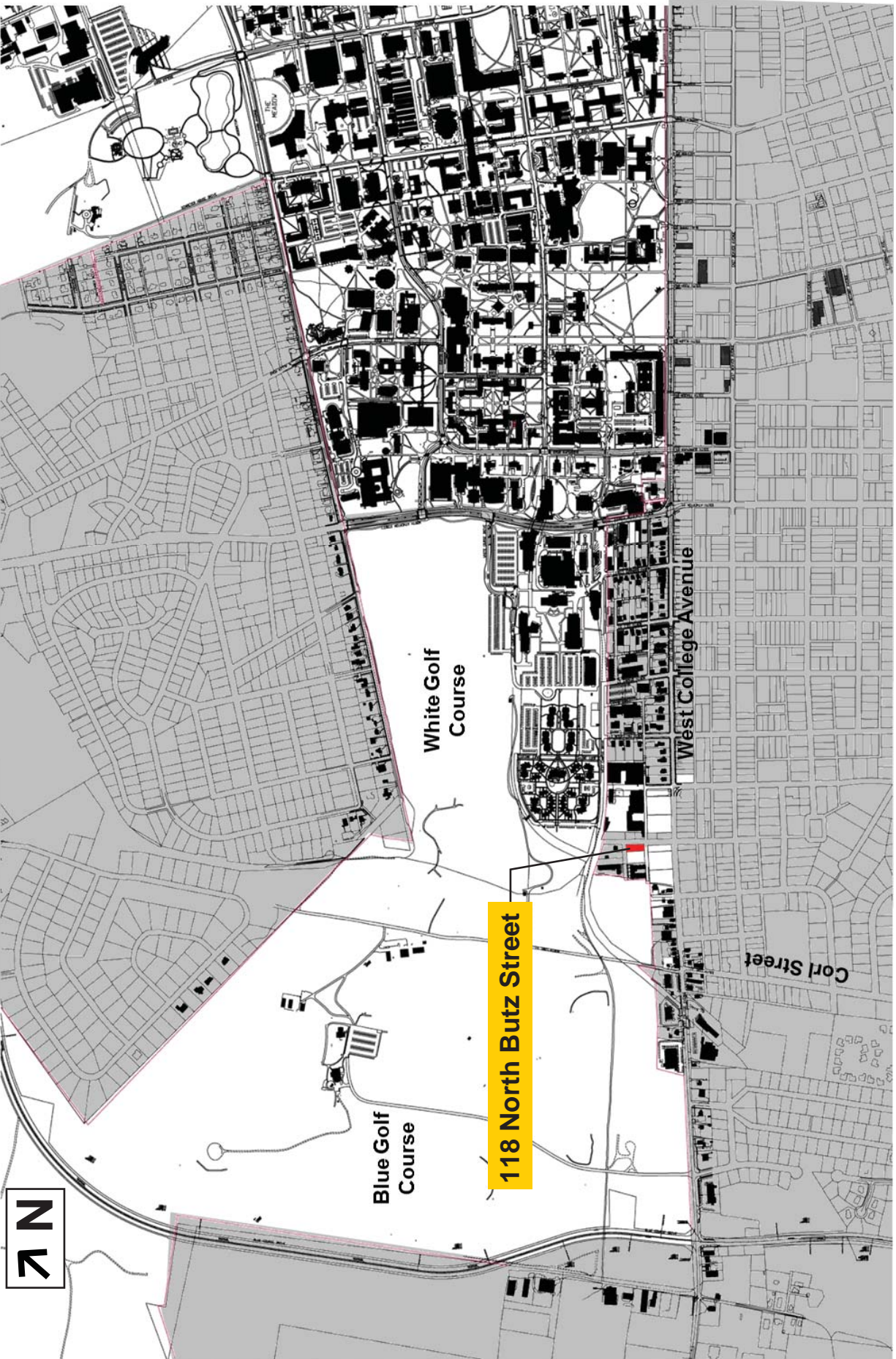

Penn State University Park



118 North Butz Street



STATUS OF MAJOR CONSTRUCTION PROGRAMS AND BORROWING (> \$5 Million)
 June 30, 2011

7/15/2011
 Bold - Completed, Italics - Projected

Campus	Project Data			Budget Amount	Commonwealth Funding	Gift Amount	BOT Milestones			Construction		Notes
	Project Name	Arch/Eng Selection	Final Plan Approval				Start Date	Completion Date				
Altoona	Port Sky Café	N/A	03/11	\$5,400,000	\$0	\$0	N/A	03/11	05/12	08/12	On HOLD. Postponed.	
Berks	Classroom / Laboratory Building	11/07	01/10	\$25,700,000	\$0	\$3,000,000	11/07	01/10	04/10	12/11	Construction is approximately 75% complete.	
Dubois	Swift Building Renovation	N/A	07/10	\$5,370,000	\$3,950,000	\$0	N/A	07/10	08/10	07/11	Construction is approximately 95% complete.	
Hershey	Children's Hospital	11/05	11/09	\$206,500,000	\$14,000,000	\$65,000,000	11/05	11/09	03/10	10/12	Construction is approximately 45% complete.	
	Support Services Building	01/09	03/10	\$19,000,000	\$0	\$0	01/09	03/10	06/10	11/11	Construction is approximately 70% complete.	
	Beaver Stadium N. End Zone and ADA Renovation	N/A	09/10	\$8,260,100	\$0	\$0	N/A	09/10	12/10	08/11	Construction is approximately 70% complete.	
	BioBehavioral Health Building	01/08	07/10	\$48,100,000	\$40,000,000	\$0	01/08	07/10	12/10	10/12	Construction is approximately 20% complete. NIH Grant funding released. Project being prepared for construction. NIH reviews ongoing.	
	Biological Research Laboratory	11/07	11/10	\$23,000,000	\$0	\$0	11/07	11/10	07/11	12/12	Project in schematic design.	
	Cedar Building Renovations	03/11	11/11	\$7,950,000	\$7,140,000	\$0	03/11	11/11	02/12	08/13	Construction started in June 2011. Construction is approximately 95% complete. Equipment start-up underway.	
	East Campus Steam Line	N/A	03/11	\$13,500,000	\$11,000,000	\$0	N/A	03/11	06/11	08/12	Construction is approximately 95% complete.	
	East Campus Steam Plant - CT/HRSG	N/A	N/A	\$18,300,000	\$0	\$0	N/A	N/A	04/10	07/11	Project program is approximately 55% complete.	
	Environmental Improvements BFP Installations	N/A	06/08	\$8,120,000	\$7,000,000	\$0	N/A	N/A	06/08	08/14	Project program is approximately 65% complete.	
	Essential Services Program	N/A	12/05	\$11,950,000	\$0	\$0	N/A	N/A	12/05	12/14	Project program is approximately 65% complete.	
	Gary Schultz Child Care Center at Hort Woods	05/08	01/10	\$11,000,000	\$0	\$0	05/08	01/10	03/10	06/11	Construction is approximately 95% complete.	
	Henderson South (Phase II)	01/08	TBD	\$56,500,000	TBD	\$0	01/08	TBD	TBD	TBD	On HOLD.	
	HUB Addition	03/11	TBD	\$25,800,000	\$0	\$0	03/11	TBD	TBD	TBD	On HOLD.	
	Pegula Ice Arena	11/10	01/12	\$89,000,000	\$0	\$89,000,000	11/10	01/12	01/12	09/13	Project in design.	
University Park	IM Building Addition	01/11	TBD	\$24,000,000	\$0	\$0	01/11	TBD	TBD	TBD	On HOLD.	
	Millennium Science Complex	03/05	09/08	\$215,000,000	\$82,550,000	\$0	03/05	09/08	09/08	07/11	Construction is approximately 95% complete.	
	Moore Building Addition	07/08	05/10	\$26,100,000	\$23,190,000	\$1,800,000	07/08	05/10	06/10	12/11	Construction is approximately 60% complete.	
	Moore Building Renovation Stage	07/08	11/11	\$21,900,000	\$20,050,000	\$1,200,000	07/08	11/11	02/12	08/13	Project in design.	
	Poilock Dining Commons Renovation	N/A	11/10	\$11,700,000	\$0	\$0	N/A	11/10	01/11	08/11	Construction is approximately 75% complete.	
	South Frear Renovations	N/A	03/11	\$6,110,000	\$2,460,000	\$0	N/A	03/11	05/11	01/13	Construction is approximately 8% complete.	
	South Halls Renovations (Phase I)	03/11	TBD	\$30,000,000	\$0	\$0	03/11	TBD	TBD	TBD	Project in schematic design.	
	Steam Production Modifications	01/11	03/12	\$25,000,000	\$0	\$0	01/11	03/12	TBD	TBD	Project in design.	
	Transformer Replacement Program	N/A	N/A	\$9,600,000	\$0	\$0	N/A	N/A	06/07	12/13	Project program is approximately 45% complete.	
	Water Treatment Plant	01/11	05/12	\$30,000,000	\$25,000,000	\$0	01/11	05/12	06/12	06/13	On HOLD.	
	West Campus Chilled Water	N/A	03/11	\$11,900,000	\$6,500,000	\$0	N/A	03/11	05/11	03/12	Construction is approximately 2% complete.	
	West Pattee Library Renovations	N/A	03/11	\$7,000,000	\$0	\$7,000,000	N/A	03/11	05/11	12/11	Construction is approximately 7% complete.	

Summary of University Long-Term Debt - \$(000) (excluding PCT)		Authorized Borrowing Status - \$(000) (excluding PCT)	
Total bonds, notes and capital leases as of June 30, 2010	\$1,088,673	Borrowing Authority per May 2007 Board of Trustees	\$600,000
Bonds, notes, and capital leases issued year to date fiscal year 2010/11	\$6,844	Capital Leases, Bonds, & Notes Issued	(\$311,274)
Year to date principal payments and premium amortizations	(\$49,496) *	Future Capitalized Leases & Anticipated Commitments	(\$3,330)
Estimated bonds, notes and capital leases as of June 30, 2011 (unaudited)	\$1,046,021	Estimated Authority Remaining	\$285,396

* Related interest expense totals approximately \$36,765

Penn State Berks

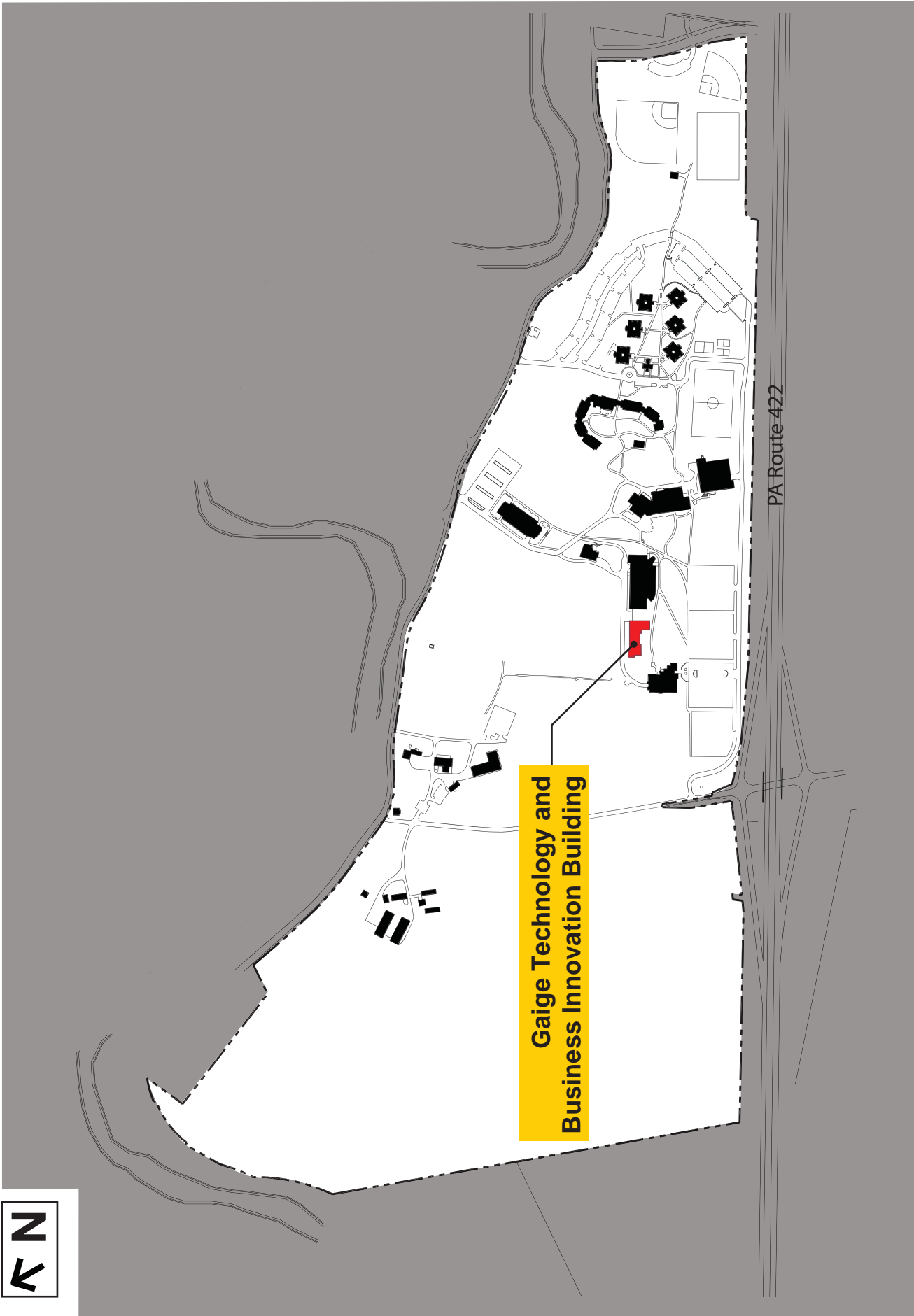

**Gaige Technology and
Business Innovation Building**

PA Route 422